

## ■ Main Vehicle Specification

CHARACTERISTIC												
Model			BR10S(J)	BR13S(J)	BR15S(J)	BR18S(J)	BR14JW	BR16JW	BR20S	BR25S		
Capacity	at rated load center	kg	1,000	1,250	1,500	1,800	1,400	1,600	2,000	2,500		
Load center	distance	mm	500	500	500	500	600	600	500	500		
Operator type	Stand - on, Rider - seated		Stand-on (Rider - seated)			Rider - seated		Stand-on				
DIMENSION												
Lift with std. two-stage mast	maximum fork height with rated load	H4	mm	3,000(3,300)	3,000(3,300)	3,000(3,300)	3,000(3,300)	3,300	3,300	3,000	3,000	
	free lift	H2	mm	320	320	320	320	320	320	347	347	
Forks	thickness × width × length	S	mm	35 × 100 × 900	35 × 100 × 900	35 × 100 × 900	35 × 100 × 900	35 × 100 × 1,050	35 × 100 × 1,050	45 × 100 × 1,000	45 × 100 × 1,000	
	fork spread (maximum/minimum)	B2	mm	720 / 200	720 / 200	720 / 200	720 / 200	720 / 200	720 / 200	830 / 200	830 / 200	
Tilt of mast	forward / backward	$\alpha/\beta$	deg	3 / 5	3 / 5	3 / 5	3 / 5	3 / 5	3 / 5	3 / 5	3 / 5	
Overall dimensions	length without forks	L	mm	1,510(1,560)	1,610(1,700)	1,710(1,800)	1,860(1,950)	1,695	1,795	1,890	2,060	
	distance to fork face	L1	mm	1,145(1,205)	1,145(1,205)	1,180(1,205)	1,180(1,245)	1,204	1,204	1,250	1,295	
	width	B	mm	1,070(1,070)	1,070(1,070)	1,070(1,070)	1,070(1,070)	1,200	1,200	1,200	1,200	
	width-load wheel	B	mm	1,078(1,118)	1,078(1,118)	1,078(1,078)	1,078(1,078)	1,208	1,208	1,250	1,250	
	width(Reach leg-Inside)	B1	mm	770	770	770	770	900	900	920	920	
	mast lowered height	H3	mm	1,984	1,984	1,984	1,984	2,135	2,135	2,006	2,006	
	mast extended height	H5	mm	3,941	3,941	3,941	3,941	4,240	4,240	4,045	4,045	
	overhead guard height	H6	mm	2,260(2,130)	2,260(2,130)	2,260(2,130)	2,260(2,130)	2,155	2,155	2,280	2,280	
	reach leg height	H7	mm	304(309)	304(309)	304(309)	304(309)	309	309	304	304	
Reach travel	V	mm	430(460)	530(560)	600(620)	750(770)	550	650	700	825		
Outside turning radius	Wa	mm	1,395(1,485)	1,495(1,585)	1,595(1,685)	1,745(1,835)	1,585	1,685	1,785	1,950		
Load moment constant (from center of wheel to fork face)	L2	mm	190	190	185(193)	195(200)	190	190	190	190		
Aisle width with pallets 800 × 1200 - Lengthwise	mm		2,635(2,697)	2,643(2,706)	2,676(2,750)	2,704(2,781)	2,715	2,726	2,783	2,842		
Aisle width with pallets 1000 × 1200 - Crosswise	mm		2,653(2,637)	2,587(2,655)	2,633(2,713)	2,692(2,773)	2,662	2,692	2,760	2,852		
PERFORMANCE												
Speeds	travel, loaded / unloaded	48V	km/h	11.5/12.0(9.5/10.5)	11.0/12.0(9.5/10.5)	10.0/11.0(9.0/10.0)	9.5/11.0(8.5/9.5)	9.5 / 10.0	9.0 / 10.0	11 / 12	10 / 12	
	lift, loaded / unloaded	48V	mm/s	290/480(290/480)	280/480(280/480)	295/535(260/480)	280/535(250/480)	260 / 420	250 / 420	280 / 420	260 / 420	
	lowering, loaded / unloaded		mm/s	500 / 450	500 / 450	500 / 450	500 / 450	500 / 450	500 / 450	500 / 440	500 / 440	
Max.gradeability	loaded / unloaded		%	18 / 23(11)	18 / 23(11)	18 / 25(9)	18 / 23(9)	9	9	13 / 23	11 / 22	
Steering	type		EPS	EPS	EPS	EPS	EPS	EPS	EPS	EPS	EPS	
WEIGHT												
Total weight - with minimum weight of battery	kg		2,110(2,100)	2,140(2,160)	2,270(2,250)	2,315(2,360)	2,350	2,370	3,070	3,110		
CHASSIS												
Tires	load	$\phi$	dia. × width	mm	254 × 120	254 × 120	254 × 120(254 × 100)	254 × 120(254 × 100)	254 × 100	254 × 100	267 × 114	267 × 114
	drive	$\phi$	dia. × width	mm	343 × 140	343 × 140	343 × 140	343 × 140	343 × 140	343 × 140	343 × 140	343 × 140
	caster	$\phi$	dia. × width	mm	165 × 60	165 × 60	165 × 60	165 × 60	165 × 60	165 × 60	203 × 76	203 × 76
Wheelbase	y	mm		1,155(1,250)	1,255(1,350)	1,355(1,450)	1,505(1,600)	1,350	1,450	1,530	1,700	
Tread width	front/rear	mm		998/600	998/600	998/600(978/600)	998/600(978/600)	1,108 / 600	1,108 / 600	1,159 / 690	1,159 / 690	
Ground clearance	loaded	at the lowest point	mm	80	80	80	80	80	80	80	80	
Service brake	type			MECH.SHOE(HYD.DRUM)			HYD.DRUM		MECH.DISC			
POWER												
Battery	volt / Capacity-Max.	V/AH		48 / 230(230)	48 / 230(268)	48 / 300(300)	48 / 300(365)	48 / 345	48 / 345	48 / 365	48 / 365	
	weight - Minimum	kg		420(420)	420(465)	510(490)	510(580)	550	550	615	615	
Motor	drive - 1Hour rating	48V	kW	3.5	3.5	3.5	3.5	3.5	3.5	5	5	
	hydraulic - 5Minutes rating	48V	kW	6(6)	6(6)	8.5(6)	8.5(6)	6	6	8	8	
	steering - 1Hour rating	48V	kW	0.3	0.3	0.3	0.3	0.3	0.3	0.3	0.3	
Control type	drive/hydraulic	type		TR / TR	TR / TR	TR / TR	TR / TR	TR / TR	TR / TR	TR / TR	TR / TR	
Relief pressure	system	kg/m <sup>2</sup>		200	200	200	200	160	175	200	200	

This specification is based on standard battery and without sidershifter.

## ■ Dimensional Drawings

(unit / mm)

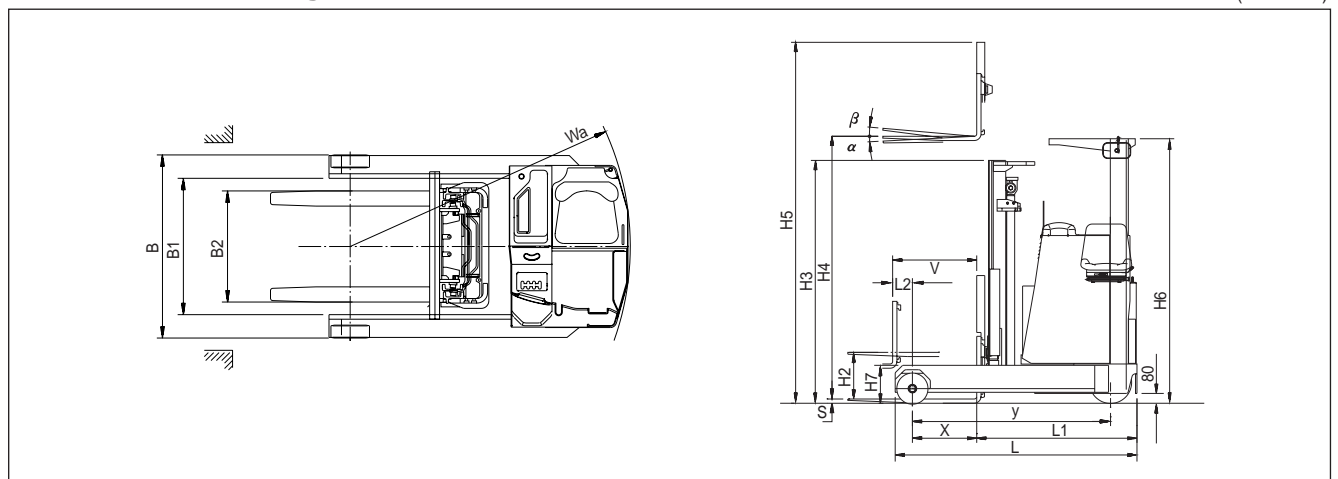

Lift your dreams with Daewoo

**5** times more braking surface than conventional shoe brakes. it's best!



## **BENEFITS OF DAEWOO'S OIL COOLED DISC BRAKES:**



- ◆ 5 TIMES MORE BRAKING SURFACE THAN COMPETITORS' SHOE BRAKES
- ◆ A COMPLETELY SEALED SYSTEM ENSURES FULL PROTECTION AGAINST CONTAMINATION
- ◆ STAND UP TO HEAT, HUMIDITY AND ABRASIVE / CORROSIVE ENVIRONMENTS
- ◆ POWER-ASSISTANCE ENHANCES OPERATORS' COMFORT
- ◆ NO ADJUSTMENT EVER NEEDED
- ◆ VIRTUALLY MAINTENANCE FREE



SC3014(Feb. 04)



**DAEWOO**  
DAEWOO HEAVY INDUSTRIES &  
MACHINERY LTD.

Head Office : 7-11, Hwasu-Dong, Dong-Gu, Incheon, Korea.

Tel : 82-32-760-1706

Fax : 82-32-760-6173

Seoul Office : 8th floor Daewoo Heavy Industries & Machinery Bldg,

14-34, Youido-Dong, Youngdungpo-Gu,

Seoul, 150-010, Korea.

Tel : 82-2-2167-3114

Fax : 82-2-3775-1504

Web site : www.daewooforklift.com

AUTHORIZED DEALER

DAEWOO products and specifications are subject to improvement and change without notice.

# DAEWOO

*Electric Reach Truck*

**1.0~2.5 Ton Series**

BR10S(J)  
BR13S(J)  
BR15S(J)  
BR18S(J)  
BR14JW  
BR16JW  
BR20S  
BR25S



# Daewoo Reach Trucks Offer Both High Power and Top Performance



The new Daewoo reach trucks are designed to operate in narrow aisles and confined spaces with high power and top performance.

Super-command control system combined with Daewoo advanced technology has created a forklift that maximizes material handling efficiency.

Fully ergonomic design with smart yellow body and black skirt and rugged structure ensure reliable operation. Compact and high powered standard trucks of 1.0 ton up to 2.5ton capacity, wide reg Reach truck of 1.4 ton up to 1.6 ton offer fast foot work, easy operation and smooth load handling in high-density warehouse.

Through high-tech mechatronics, Daewoo offers a totally new concept on material handling.



# Operator Compartment



## Operator Compartment

The ergonomically designed operator compartment has conveniently placed controls and instruments which allow the operator to prolong the work cycle, increase productivity and reduce costs with more loads moved in less time. Anti-slip soft rubber floor mat is provided as standard.



### 1 Levers

Reduced effort control valve lever provides smooth control of hydraulics.

### 2 Spacious Leg Room and Pedals

The large accelerator and brake pedal give less pedal effort and optimum angle for quick shift braking. The one-piece type floor mat gives a clean look and a non-slip surface.

### 3 High Visibility Mast & Carriage

Clear view mast and carriage enhance operating efficiency.

### 4 Easy Battery Pull-In & Out

The reach operation can be used to pull the battery out of its compartment. In addition, the side draw function is available too as an option.

### 5 Low Noise Hydraulic Pump & Motor

A single, variable speed hydraulic motor and Stealth pump provide smooth and quiet lifting operations.

# Durability and Serviceability

## Easy Maintenance

Wide open reardoor enables operator to check and adjust the motor, including brake. Especially integrated grease fitting prolongs equipment life, and assist operator in daily-check.



## Central Vehicle Monitoring System

Twin 7-segment and graphic symbol LCD provides a battery discharge indicator, power duty, diagnostic information, fault codes, lift interrupt, thermal and brush wear indicator. A separate hour meter is also provided.



### Battery Discharge Indicator Symbol

The logics constantly monitor the battery capacity and the LCD displays the remaining level of charge.



### Park Brake Symbol

If the park brake is applied, the park brake symbol will illuminate to warn the operator and drive will be prevented.



### Built in Diagnostic System Symbol

Displays reference codes from the 'Run Time diagnostics' and 'self diagnostics' analyser functions in the logics.



### Drive Speed Indicator Symbol

## Overheat Signals

If the motors or controller overheat the relevant indicator will light on the LCD panel and the truck performance will be reduced to protect the system.



Hydraulic Motor Overheat Signal



Controller Overheat Signal



Drive Motor Overheat Signal

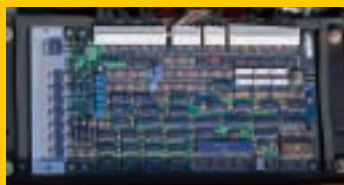

## Microprocessor Monitors Truck Components

The lift trucks electronic brain is a microprocessor control panel. The microprocessor provides 'run time

diagnostics' as well as 'self-diagnostics' fault finding. With 'run time' diagnostics, the microprocessor continually monitors the truck's performance and alerts the operator to problems. Built in self-diagnostics help service engineers check for electrical malfunctions without the need for expensive external test equipment. Numerous functions can be programmed as standard to suit operating conditions.